

## Emergency shut-off (open) motorized actuator

# PMK-SRF

The PMK-SRF is an electrical spring return type actuator that does not require a power supply unit and protects your piping from damage during emergencies. It serves as a safety countermeasure for various fluid lines, from water, sewage and steam lines, to chemical and powder lines.



### ■ Features

- Reliable motorized spring return system
- Does not require a power supply unit
- On and off operations, proportional control, and emergency shut-off all in one device

PMK-SRF Type Standard Specifications							
Type	PMK-005SRF		PMK-010SRF		PMK-030SRF		
Output torque	49N·m		98N·m		294N·m		
Motor power source	AC100V 50/60Hz	AC200V 50/60Hz	AC100V 50/60Hz	AC200V 50/60Hz	AC100V 50/60Hz	AC200V 50/60Hz	
Current value (A)	Rated	0.5	0.25	0.5	0.25	1.0	0.5
	Startup	1.2	0.6	1.2	0.6	4.0	2.0
Travel time (50/60Hz) (sec)	Opening and closing	18/15		36/30		66/55	
	Emergency shut-off (return)	Max. 3		Max. 5		Max. 10	
Power consumption (VA)	Rated	50	50	50	50	100	100
	Startup	120	120	120	120	400	400
Time rating	30 minutes						
No. of poles	4						
Insulation	Class E						
Motor protection	Thermal protector						
Space heater	Option						
Position limit switch	One each for fully open and fully closed (contact capacity: AC250V, 10A)						
Torque limit switch	None						
Mechanical limit stop	End of travel positioning bolt built-in						
Conduit connections	G3/4 at two ports						
Enclosure	JIS C 0920, Class 4, dust and water-jet proof type (Equivalent IP54)						
Manual operation	None						
Ambient temperature	- 10 to 50 degrees C						
Coating	Silver hammer net (Munsell N7)						
Position	Horizontal/vertical 180° range (Do not install upside down.)						
Options	① Potentiometer (135 Ω, 500 Ω)						
	② Electro-electro Positioner (4 to 20 mA DC I/O)						

Note: A sun cover is required if you will be using this product outdoors. For details please consult us.

### PMK-SRF Dimensions

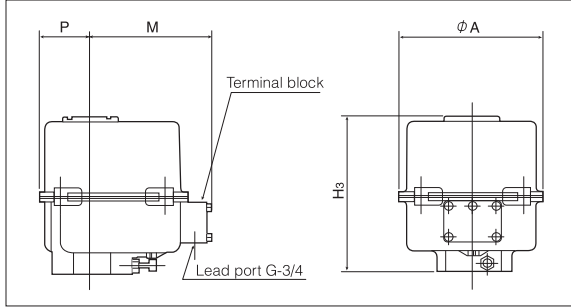

### PMK-SRF Dimensions / Weight

Type	Dimension (mm)				Approx. Mass (kg)
	A	M	P	H <sub>3</sub>	
PMK-005SRF	205	191	70.5	221	9
PMK-010SRF	205	191	70.5	284	10
PMK-030SRF	240	215	88	342	23

### PMK-SRF Circuit and Explanation of Operation

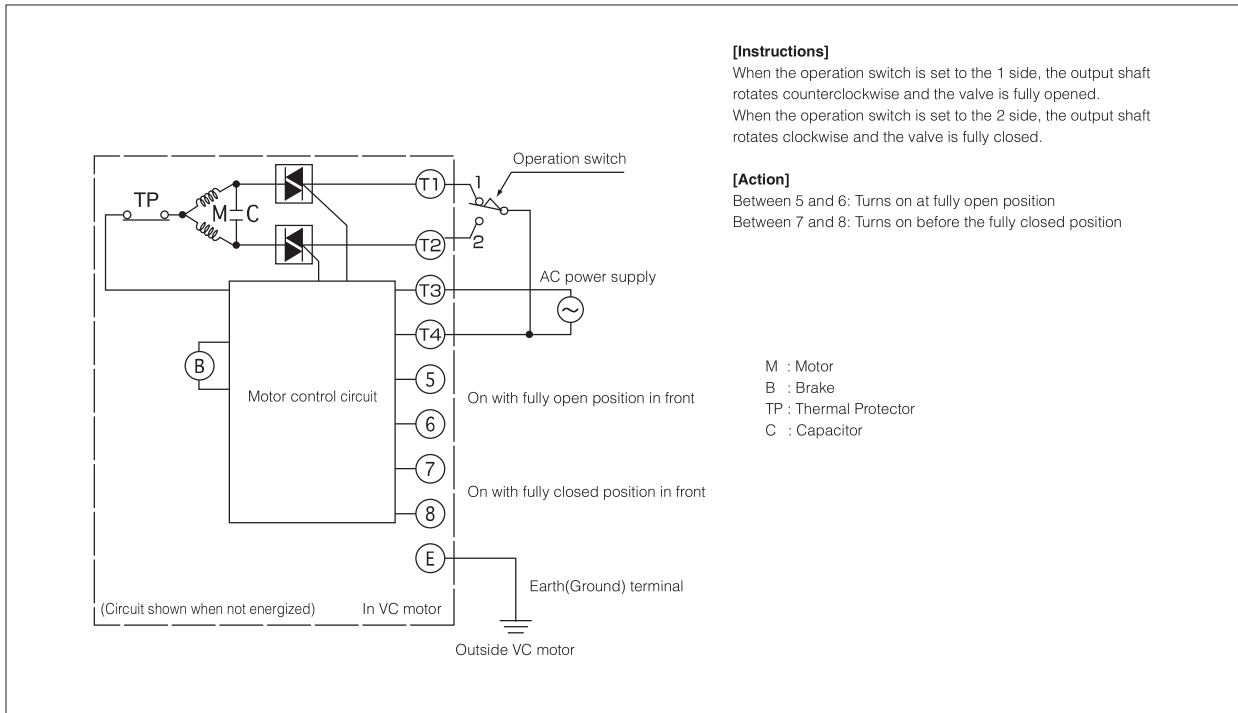

- Actuator**
- New ELMY 41**
- New MICON ELMY II 41**
- PMK-SRF 4K**
- SRJ 4J**
- LTKD 4L**
- New T-DYNAMO 7E/7F/7G**
- TGA 3A**
- TG-S 3K/3U**
- 3C**
- Diaphragm 6X/6W/6Z/6A/6B**
- Hydraulic cylinder 3H**
- Manual Actuators 17/1J/2U/2I/2S/2G/2R**